

WHEEL STOPPER

Suitable for light commercial vehicles



Wheel stopper are designed to improve car park safety and are ideal for both small and large commercial car parks or even a residential parking area. Our rubber wheel stopper are the preferred choice of industrial sites, retail parks, hospitals, car park operators and commercial.

- Prevents damage to property and protects pedestrian walkways
- Reflective tape is molded, for increased visibility

Protector[®]



N.H Enterprises

🌐 nhenterprises.pk
✉ info@nhenterprises.pk
☎ +92 333 3516881

Lahore:

+92 331 4418990 | lahore@nhenterprises.pk

Islamabad:

+92 345-2340752 | Islamabad@nhenterprises.pk

Factory Address:

Plot B36 Irshad Qadri Road SITE Karachi.

RUBBER WALL GUARDS

- Easy to Install
- Dimensional accuracy
- Yellow reflective strip
- One Piece Construction
- Durability

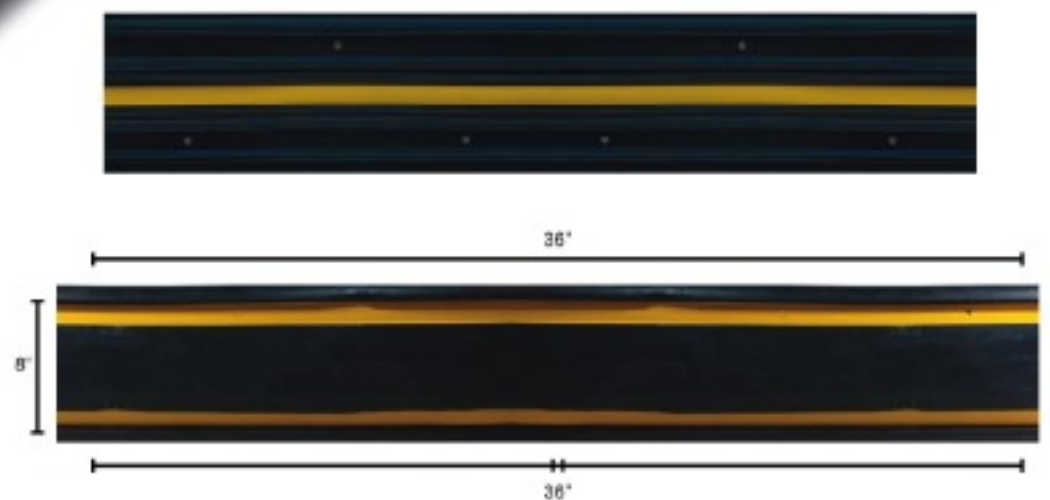

Prevent those little bumps from turning into big damage with a rubber wall guard. This simple addition absorbs and minimize damage when a heavy or light vehicle accidentally contacts a wall. The wall guard is resistant to water, oil, UV light and extreme temperatures, so it can be used indoors or outdoors. in commercial or retail areas, parking structures, warehouse, industries or even a home garage.

- The wheel when set against the rubber chocks experiences the flexibility
- Unique capability of rubber chokes is possible due the equilateral round shape
- Distinct internal design of the product

Protector[®]



N.H Enterprises

🌐 nhenterprises.pk
✉ info@nhenterprises.pk
☎ +92 333 3516881

Lahore:

+92 331 4418990 | lahore@nhenterprises.pk

Islamabad:

+92 345-2340752 | Islamabad@nhenterprises.pk

Factory Address:

Plot B36 Irshad Qadri Road SITE Karachi.

Protect Column & Wall Edges

INDUSTRIAL & BUILDING SAFETY PRODUCTS

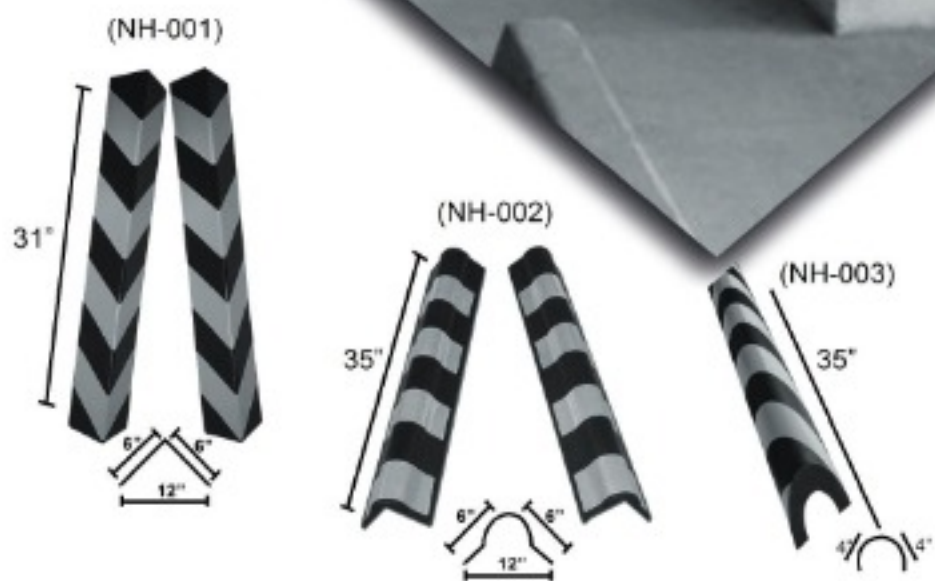

The rubber compound makes a perfect protector of columns and corners because it is inexpensive and easy to maintain. The rubber will not wrap, crack, chip or rot.

Quick installation - Corner Protectors are installed using screws or epoxy adhesive (not supplied) onto concrete or steel columns. They are lightweight, easy to handle and can easily be installed by one person.

Yellow Delineation - Our Corner Protectors have yellow reflective strips making the corner and the protector clearly visible to motorists and pedestrians both day and night.

All Size of Rubber Column Guard

Model No.	Shape	Length	Width	Thickness	Weight
NH-001	Arrow Shape	35" Approx	4"x4" Approx	10-12mm	2.6 Kg
NH-002	D. Shape	40" Approx	4"x4" Approx	10-12mm	2.8 Kg

You can order customize design or size.

Protector[®]



nhenterprises.pk
info@nhenterprises.pk
 +92 333 3516881

Lahore:
 +92 331 4418990 | lahore@nhenterprises.pk
Islamabad:
 +92 345-2340752 | Islamabad@nhenterprises.pk
Factory Address:
 Plot B36 Irshad Qadri Road SITE Karachi.

Protector[®]

Neoprene Bearing Pads

Rubber Bearing for Bridge and Construction



 nhenterprises.pk
 info@nhenterprises.pk
 +92 333 3516881

Lahore:
+92 331 4418990
lahore@nhenterprises.pk

Islamabad:
+92 345 2340752
islamabad@nhenterprises.pk

Black neoprene bearing pad is used as economical efficient bearing plates for pre-cast, pre-stressed concrete or steel beams in bridges and buildings. Neoprene Pads permit a smooth and uniform transfer of load from the beam to the substructure, allow beam rotation at the bearing due to deflection of the beam under load. They further allow lateral and longitudinal movement of the beam caused by thermal forces.

Neoprene Pads have no moveable parts and thermal expansion and contraction are absorbed by the pad's ability to give and take in shear. There is no sliding between pad and beam or between pad and abutment.

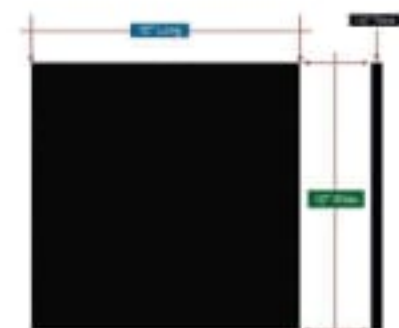

Protector[®]

Bridge Expansion Rubber Joints

- Motorways
- Road Bridges



nhenterprises.pk
info@nhenterprises.pk
[+92 333 3516881](tel:+923333516881)

Lahore:
[+92 331 4418990](tel:+923314418990)
lahore@nhenterprises.pk

Islamabad:
[+92 345 2340752](tel:+923452340752)
islamabad@nhenterprises.pk

DESCRIPTION

Rubber bridge expansion joints are mainly made of rubber, steel plate and angle iron. Steel plates are set in the rubber bridge expansion to strengthen the bearing capacity and they can slide freely along the angle iron to meet the expansion deformation of main grid.

Because of the excellent sealability and shock-absorbing effect of rubber, rubber bridge expansion joints do well in proofing water and reducing noise. The elasticity of rubber plates and its shear deformation in the telescopic channel helps the whole device to realize telescopic motion.

Features

Rubber bridge expansion joints made of prime-quality rubber are anti-aging and have a long service life. Being wear-resistant, this product can withstand reiteration function of vehicle load. During installation, bolt holes on the bottom and each junction are filled with adhesion agent which makes the whole rubber bridge expansion joints be highly water-resistant.

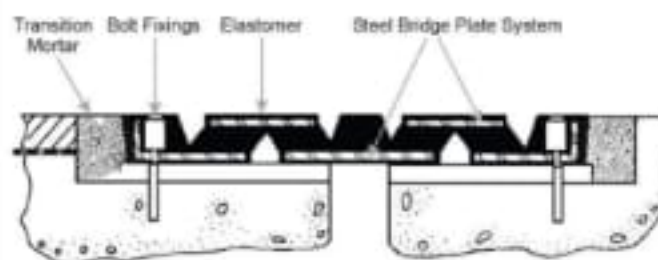

Typical cross section through the fitted joint



N.H Enterprises



MEDIAN MARKER

are extremely durables devices providing day and night visibility



Info@nhenterprises.pk

0333-3516881

www.nhenterprises.pk

TYRE KILLERS

Tyre Killers series are widely used in highway toll station, checkpoints, prisons, airports, government agencies, embassies, custom ports, many more..

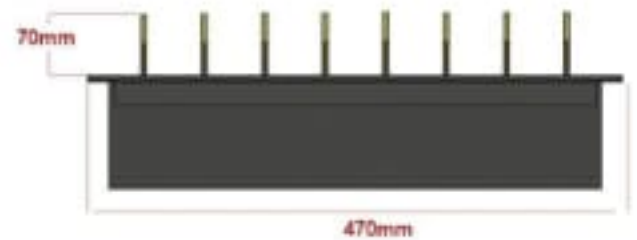
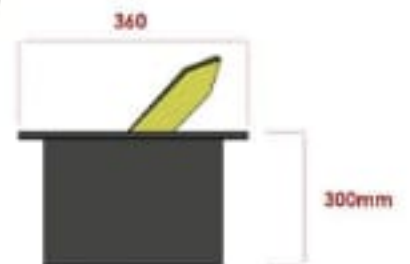
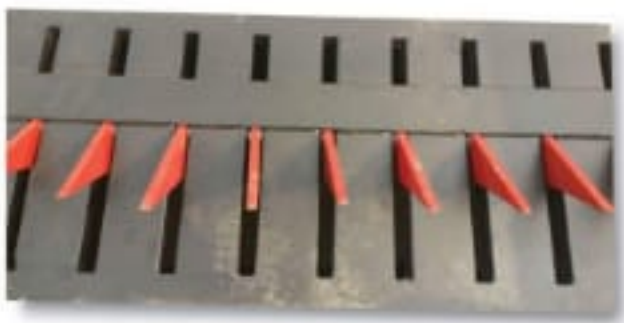

Tyre Killers are an effective one-way traffic control product, improved with the traffic calming effect of a speed ramp. Comprised of a simple and reliable, vehicle operated mechanical system they are quick and easy to install onto concrete and most asphalt road surfaces with no excavation required.

Protector[®]



N.H Enterprises

nhenterprises.pk
info@nhenterprises.pk
[+92 333 3516881](tel:+923333516881)

Lahore:
[+92 331 4418990](tel:+923314418990) | lahore@nhenterprises.pk
Islamabad: [+92 336 0156155](tel:+923360156155) (Protector: Rizwan)
[+92 345 2340752](tel:+923452340752) | islamabad@nhenterprises.pk

WHEEL STOPPER ALUMINUM

High visibility Road Stud LEDs and reflective glass elements incorporated into the Solar Base Parts help ensure safe driving at night.



Material Detail:

Aluminum Casting
Laminated with 3m media
Finished with superior polish

Installation Procedures:

Holes with L.T machine P Pour epoxy in it and press it.

Dimensions:

Length 385mm
Width 1.5mm
Height 55mm
Weight 4kg each pair

Protector[®]



N.H Enterprises

 nhenterprises.pk
 info@nhenterprises.pk
 +92 333 3516881

Lahore:
+92 331 4418990 | lahore@nhenterprises.pk
Islamabad: +92 336 0156155 (Protector: Rizwan)
+92 345 2340752 | islamabad@nhenterprises.pk

Wheel Chock

Safe &
Secure Grip

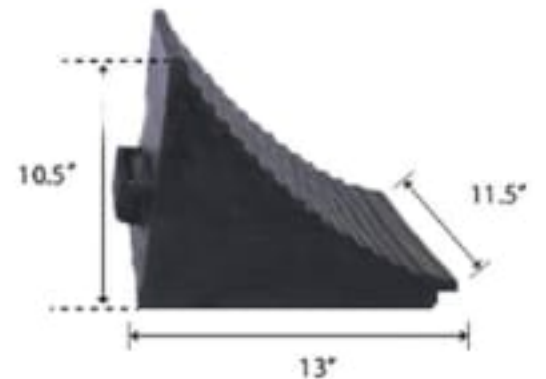

15 Kg HD-WC-02

For Cars, Suvs, Heavy and Mini Trucks

Wheel chocks help prevent vehicles and equipment from accidentally moving during loading and unloading of cargo. Wheel chocks are contoured to fit vehicle tires and prevent any possible slippage.

- Heavy-duty rubber wheel chocks
- Standard rubber wheel chocks

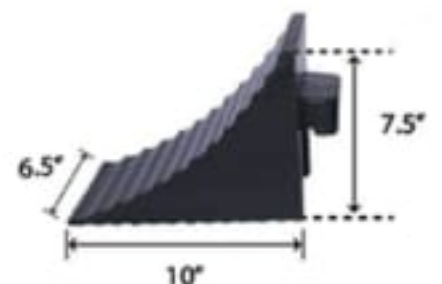

4.5 Kg HD-WC-01

Protector[®]



N.H Enterprises

nhenterprises.pk
info@nhenterprises.pk
[+92 333 3516881](tel:+923333516881)

Lahore:
[+92 331 4418990](tel:+923314418990) | lahore@nhenterprises.pk
Islamabad: [+92 336 0156155](tel:+923360156155) (Protector: Rizwan)
[+92 345 2340752](tel:+923452340752) | islamabad@nhenterprises.pk

JERSEY BARRIERS

Lightweight design,
no heavy equipment
needed

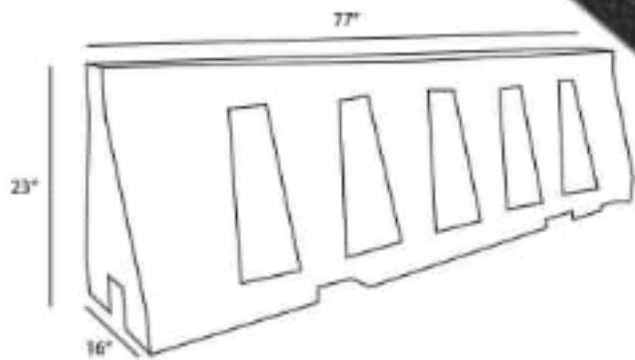

The Plastic Jersey Barriers can be accessorized to be used as a barrier wall and to securely mount warning flags, steady burning lights, or flashing lights for increased visibility. Colors include high visibility orange and white.

Composition: 100% Polyethylene
Dimension: 77"x16"x23"
Weight: 15-16 Kgs (Empty)
200 Kgs (With Water)
350 Kgs (With Sand)
Color: Red and White



N.H Enterprises

nhenterprises.pk
info@nhenterprises.pk
[+92 333 3516881](tel:+923333516881)

Lahore:
[+92 331 4418990](tel:+923314418990) | lahore@nhenterprises.pk
Islamabad:
[+92 345 2340752](tel:+923452340752) | islamabad@nhenterprises.pk

RUBBER RUMBLE STRIPS

Emergency traffic control
Lane closures
Traffic safety check-points

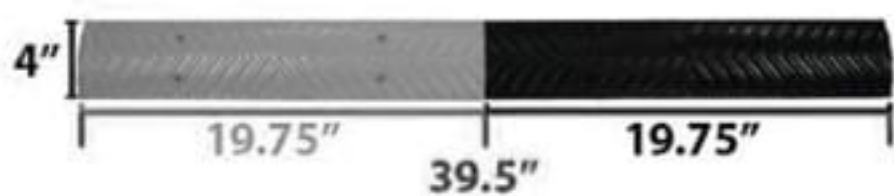

Length: 39.5" (2 Pieces)
Width: 4"

Excellent for reducing speed and alerting motoring public to changes in their normal driving environment. Great for giving advance notice of upcoming construction, speed reduction or school zones.

Protector[®]



nhenterprises.pk
info@nhenterprises.pk
[+92 333 3516881](tel:+923333516881)

Lahore:
[+92 331 4418990](tel:+923314418990) | lahore@nhenterprises.pk
Islamabad: [+92 336 0156155](tel:+923360156155) (Protector: Rizwan)
[+92 345 2340752](tel:+923452340752) | islamabad@nhenterprises.pk

Rubber Speed Humps

- SYNTHETIC RUBBER MATERIAL
- SOLD BLACK & YELLOW COLOR

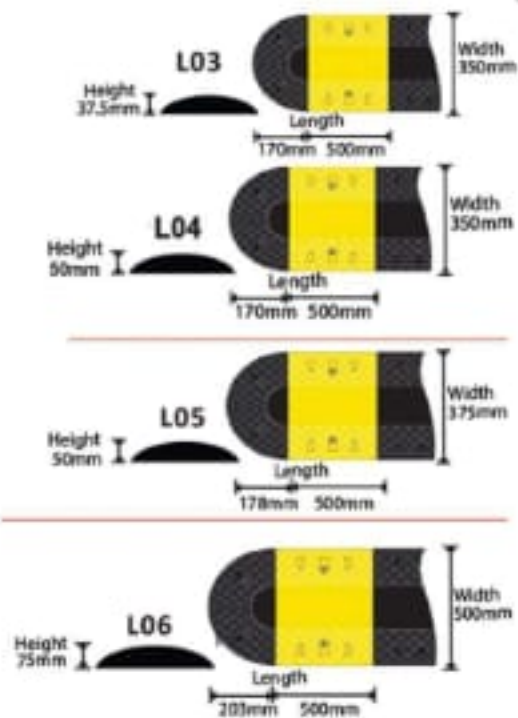

Speed Bumps and Humps are an easy way to deter excessive speed. We offers various types of speed bumps and road humps that will slow down traffic and offer pedestrians more security as they walk from their cars to their jobs.

- Includes all mid-sections, end-caps and fixings
- Ideal for Residential and Commercial areas
- Highly Durable
- Quick and Easy Install

Protector[®]



N.H Enterprises

nhenterprises.pk
info@nhenterprises.pk
[+92 333 3516881](tel:+923333516881)

Lahore:
[+92 331 4418990](tel:+923314418990) | lahore@nhenterprises.pk
Islamabad: [+92 336 0156155](tel:+923360156155) (Protector: Rizwan)
[+92 345 2340752](tel:+923452340752) | islamabad@nhenterprises.pk

SOLAR LED CATEYE

High visibility Road Stud LEDs and reflective glass elements incorporated into the Solar Base Parts help ensure safe driving at night.



High visibility Road Stud LEDs and reflective glass elements incorporated into the Solar Base Parts help ensure safe driving at night. The Solar Base Parts are solar powered, allowing them to be used in remote or stand alone applications. High performance Nickel-Metal Hydride Battery along with completely waterproof packaging ensures maintenance-free, Only clean solar energy is used; there are no hazardous materials in the products.

Protector[®]



nhenterprises.pk
info@nhenterprises.pk
[+92 333 3516881](tel:+923333516881)

Lahore:
[+92 331 4418990](tel:+923314418990) | lahore@nhenterprises.pk
Islamabad: [+92 336 0156155](tel:+923360156155) (Protector: Rizwan)
[+92 345 2340752](tel:+923452340752) | islamabad@nhenterprises.pk

RUBBER INTERLOCKING FLOOR TILE Matt

- PLAIN SURFACE
- TEXTURED SURFACE
- THICKNESS 12 mm

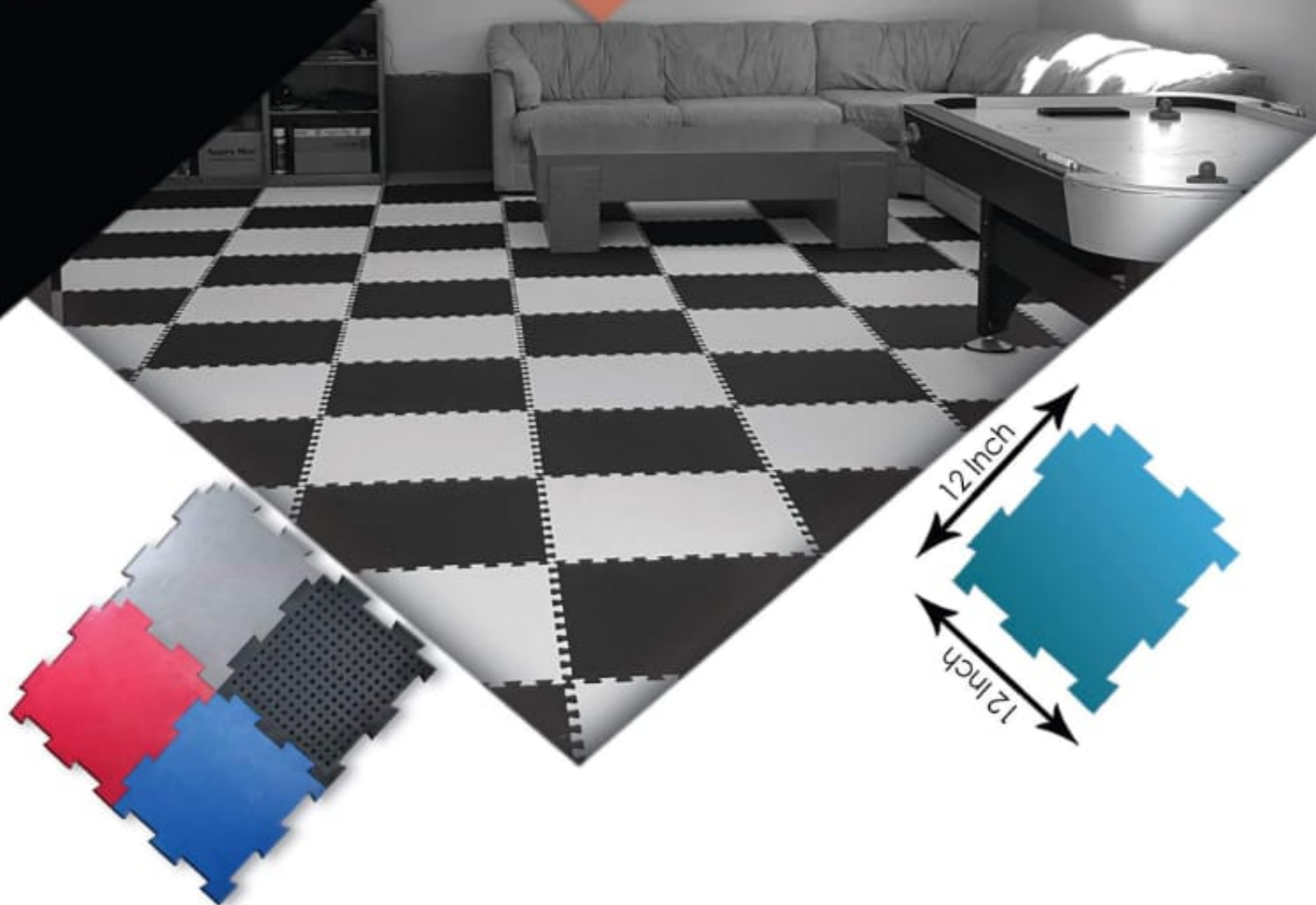

Interlocking rubber flooring can be installed easily over nearly any smooth surface including concrete, asphalt, wood or tile. No special tools are required. The unique tab design holds the tiles together securely without the need of expensive adhesives, tapes or the labor to apply them

Usage:

Gym, office, factories, hospitals, hotels, laboratories, laundries, bathroom, shops, supermarkets and skating rinks all have one thing in common – the need to provide a safe and comfortable medium for user. Interlocking rubber flooring can be installed easily over nearly any smooth surface including concrete, asphalt, wood or tile. No special tools are required. The unique tab design holds the tiles together securely without the need of expensive adhesives, tapes or the labor to apply them

- Good energy absorption.
- Reliable performance
- Durable standards
- Choose color options.
- Coin Texture mat non-slip surface.
- Floor protection.

Protector[®]



nhenterprises.pk
info@nhenterprises.pk
[+92 333 3516881](tel:+923333516881)

Lahore:
[+92 331 4418990](tel:+923314418990) | lahore@nhenterprises.pk
Islamabad: [+92 336 0156155](tel:+923360156155) (Protector: Rizwan)
[+92 345 2340752](tel:+923452340752) | islamabad@nhenterprises.pk

RUBBER LANE DIVIDER

Highest
Visibility to the
median during
Night & Enhanced
Safety of Motorists
and Vehicle



Lane Dividers are designed to perform a wide variety of traffic management purposes like indicating lane separation, cycle lanes, parking bays, and tramways. They also mark traffic lanes in car park entrances and exit ramps and protect tunnel walls from possible vehicle impact damage. When used with optional reflective panels, they are ideal for low light areas such as underground passages.

Protector[®]



N.H Enterprises

 nhenterprises.pk
 info@nhenterprises.pk
 +92 333 3516881

Lahore:
+92 331 4418990 | lahore@nhenterprises.pk
Islamabad: +92 336 0156155 (Protector: Rizwan)
+92 345 2340752 | islamabad@nhenterprises.pk

RUBBER DOCK FENDERS

Protecting Loading Dock Stations & Vehicles from Damage.

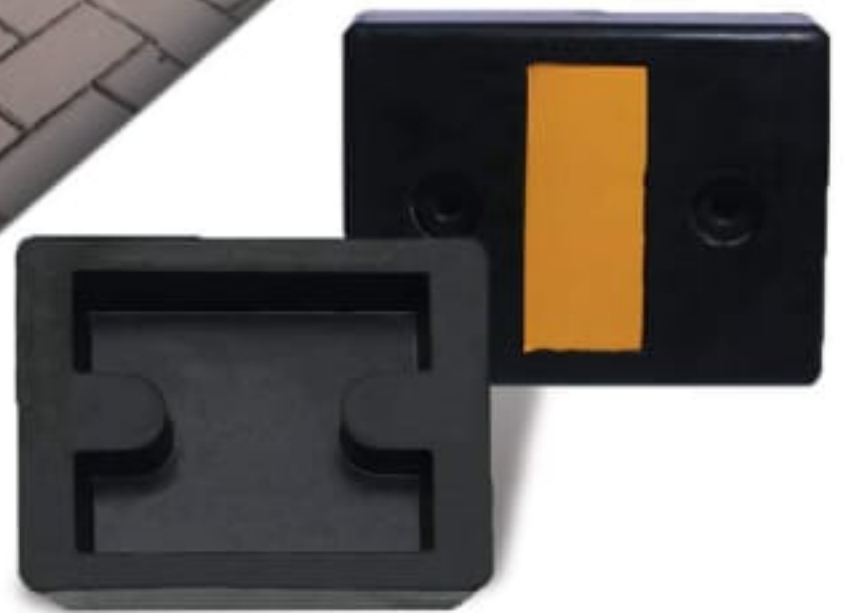
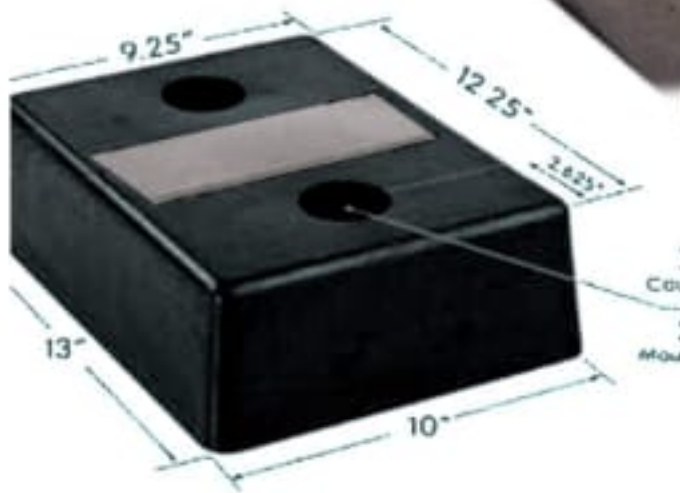

We offer a comprehensive range of moulded and extruded marine rubber fenders which are cost effective and efficient solutions to suit any operating environment, condition and requirement. The principle purpose of a rubber fender system is to protect the hull and berthing facility from damage when vessels berth alongside. The fender functions as a shock absorber by absorbing the berthing energy of a vessel on berthing facility.

- Standard Rubber Dock fenders
- Extra-length loading Rubber Dock fenders
- Extra-thick loading Rubber Dock fenders

Protector[®]



N.H Enterprises

nhenterprises.pk
info@nhenterprises.pk
[+92 333 3516881](tel:+923333516881)

Lahore:
[+92 331 4418990](tel:+923314418990) | lahore@nhenterprises.pk
Islamabad: [+92 336 0156155](tel:+923360156155) (Protector: Rizwan)
[+92 345 2340752](tel:+923452340752) | islamabad@nhenterprises.pk

ALUMINUM SPEED BREAKER (HEAVY WEIGHT)

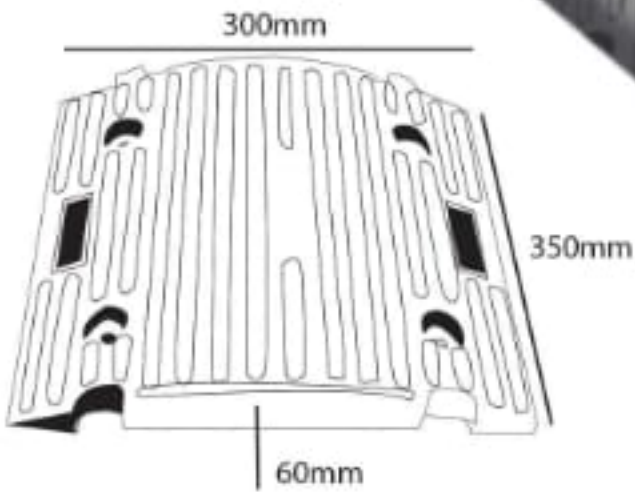
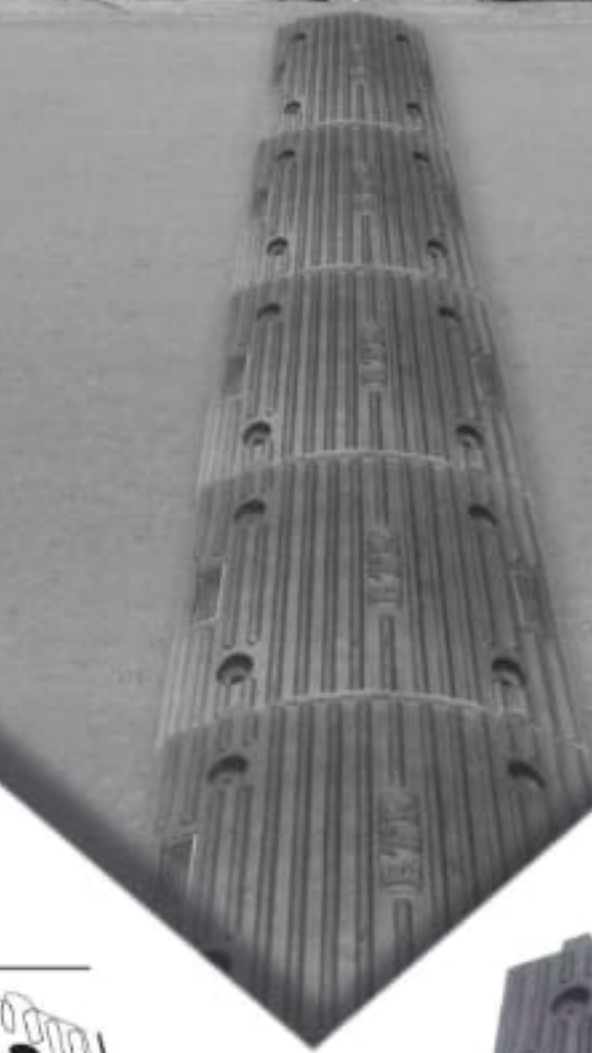

Material Detail:

Aluminum Casting
Laminated with 3m media
Finished with superior polish

Installation Procedures:

Four holes with L.T machine and
pour epoxy fixed with rawal bolt

Dimensions:

Length 300mm
Width 350mm
Height 60mm
Weight 8.5kg

Protector[®]



N.H Enterprises

nhenterprises.pk
info@nhenterprises.pk
[+92 333 3516881](tel:+923333516881)

Lahore: +92 331 4418990 | lahore@nhenterprises.pk

Islamabad: +92 336 0156155 (Protector: Rizwan)
+92 345 2340752 | islamabad@nhenterprises.pk